

CAUTION: READ INSTRUCTIONS CAREFULLY BEFORE STARTING INSTALLATION

INTRODUCTION

The HI-4 ignition system is intended for use with Harley-Davidson® motorcycles. The HI-4 replaces the O.E. (original equipment) electronic ignition system on 1978 and later models and the points and mechanical advance on early models.

The HI-4 features state-of-the-art RISC microcontroller technology that allows adjustable advance and rev limit. A timing LED indicates static timing (top dead center) and gives diagnostic information. Two starting modes are provided: electric start and kick start. A tach output gives accurate tach readings even at the rev limit.

WARNING: 1996 MODELS HAVE A VEHICLE ATTITUDE (TILT) SENSOR THAT SHUTS OFF THE IGNITION WHEN THE MOTORCYCLE ROLLS ON ITS SIDE. THIS FEATURE IS DISABLED WHEN THE HI-4 IGNITION IS INSTALLED.

NOTE: HI-4 Single Fire Race Ignition 8-2100 is for off road racing and early O.E. points applications only.

ADDITIONAL REQUIRED PARTS

FX series Big Twin® and XL series Sportster® models prior to 1984, FL series Big Twin® models prior to 1985, and all models with O.E. points will require H-D® timing rotor P/N 32402-83. This part is not included with the HI-4 installation kit and can be purchased from your local dealer.

COIL AND SPARK PLUG CABLE CONSIDERATIONS

We recommend replacing the O.E. coil. Coils used with the HI-4 must have at least 2 ohms primary resistance. Coils with 4 ohms or higher may be used, but may not produce optimum output. We recommend the following coils for single and dual-plug applications:

HI-4 Ignition With Single Plug Heads. Use Crane 8-3001 coil. This is a "Siamese" coil with two independent sections and will fit in the stock mounting location on most H-D® motorcycles. You can also use two dual spark tower coils and ground one of the towers on each coil to the engine case or frame. You will have to fabricate a bracket to mount the second coil.

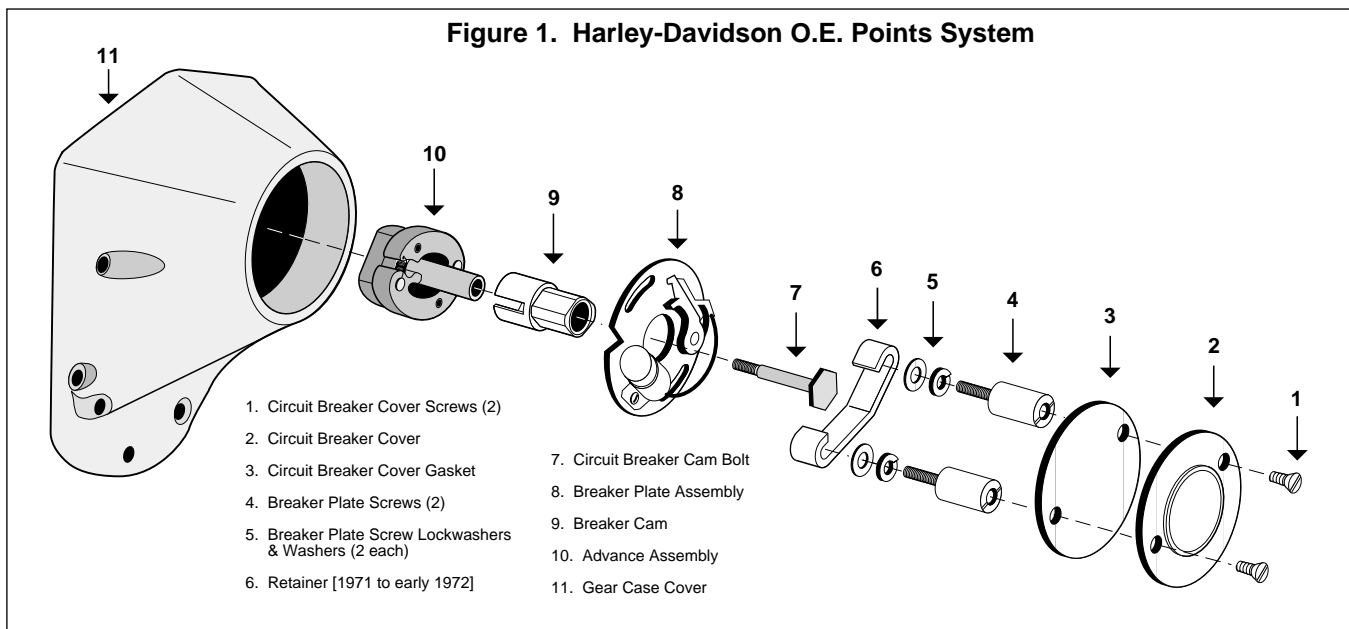

CRANE CAMS, INC. 530 Fentress Blvd., Daytona Beach, FL 32114
Tech Line: (904) 258-6174 Fax: (904) 258-6167

Figure 2. Harley-Davidson 1978-79 O.E. Electronic System

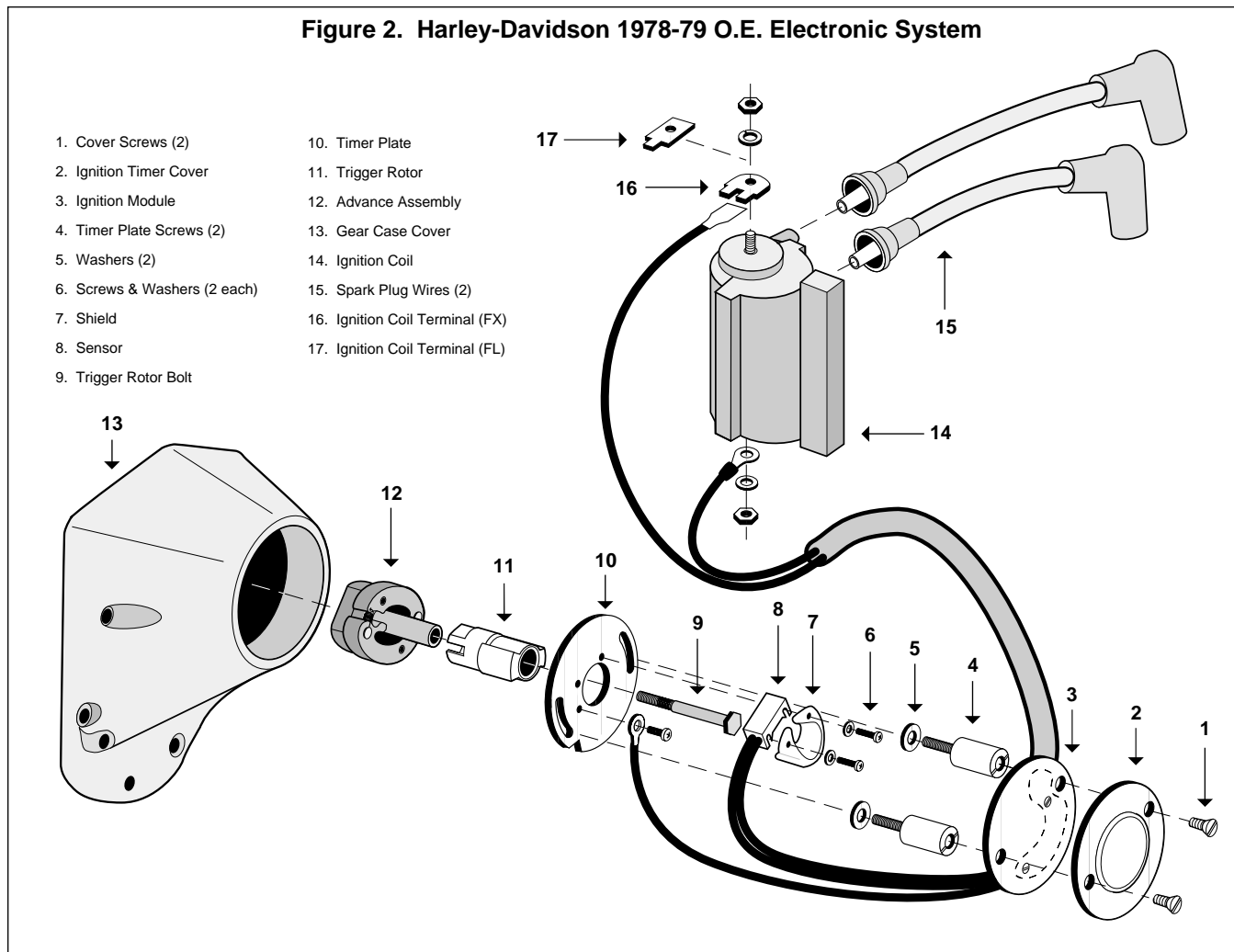

HI-4 Ignition With Dual Plug Heads. Use two Crane 8-3002 coils. You will have to fabricate a bracket to mount the second coil.

Crane HI-Intensity Reactive Core spark plug wires or equivalent spiral core wires are recommended for maximum performance. Do not use solid copper spark plug cables; they may cause interference with your ignition system and accessories.

REMOVAL OF POINTS IGNITION - EARLY MODELS PRIOR TO 1978

1. Turn ignition switch off and disconnect battery ground cable. Disconnect wire going from breaker points to Coil – (negative) terminal.
2. Refer to Figure 1. Remove ignition cover plate, gasket, and hardware (items 1-3). Save these items for later re-use.
3. Note location of breaker plate. There is a V notch in the breaker plate used for alignment. When you install the HI-4, align the V notch in the same location. This should set the timing close enough to start the engine. Remove and save the two standoffs and washers (items 4-5). Remove the breaker plate assembly, wiring, cam, and advance assembly (items 6-10).

REMOVAL OF O.E. ELECTRONIC IGNITION SYSTEM - 1978 AND 1979 MODELS

1. Turn ignition switch off and disconnect battery ground cable.
2. Refer to Figure 2. Disconnect wires going from ignition module (item 3) to coil (14).
3. Remove ignition cover plate and hardware (items 1 and 2). Save these items for later re-use. Remove ignition module (3).
4. Note location of timer plate (10). There is a V notch in the timer plate used for alignment. When you install the HI-4, align the V notch in the same location. This should set the timing close enough to start the engine. Remove and save the two standoffs and washers (items 4-5). Remove the sensor, shield, timer plate, trigger rotor, and advance assembly (items 6-12).

REMOVAL OF O.E. ELECTRONIC IGNITION SYSTEM - 1980 AND LATER MODELS

1. Turn ignition switch off and disconnect battery ground cable.

2. Refer to Figure 3. Remove O.E. ignition module and wire harness (items 1-4). You will disconnect two wires at the coil, wire going to the VOES (Vacuum Operated Electrical Switch), ground wire at the module, and the 3 pin plug (20) that connects to the sensor plate.
3. Remove ignition cover plates and gasket (items 5-9). This will require drilling out two rivets. The rivets will later be replaced with two supplied self threading screws.
4. In order to remove the sensor plate cable, the cable plug (20) must be removed first. Use needle nose pliers to pull the terminals out of the plug. Then pull the cable through the exit hole at the bottom of the timing cover.
5. Note location of sensor plate (11). There is a V notch in the sensor plate used for alignment. When you install the HI-4, you should align the V notch in the same location. This should set the timing close

enough to start the engine. Remove and save the two standoffs and washers (10). Remove the sensor plate (item 11).

HI-4 INSTALLATION

Refer to Figure 4. The HI-4 requires H-D timing rotor P/N 32402-83. Check your rotor (9) for correct part number. For models prior to 1980, use the supplied 10-32 x 3/4" bolt and washer to mount the rotor.

1. Install HI-4 system in place of O.E. breaker or sensor plate. Rotate the HI-4 about 90 degrees to give better access to the cable exit hole in the gear case cover. On some early models it may be necessary to enlarge this hole. Install the HI-4 first, then push the cable through the hole. Align the V notch on the HI-4 same as the O.E. plate you removed. Use the O.E. standoffs to secure the HI-4. You must use lock washers under the standoffs for proper clearance between the HI-4 and cover plate. Do not fully tighten the standoffs until the timing has been set.

Figure 3. Harley-Davidson 1980 and Later O.E. Electronic System

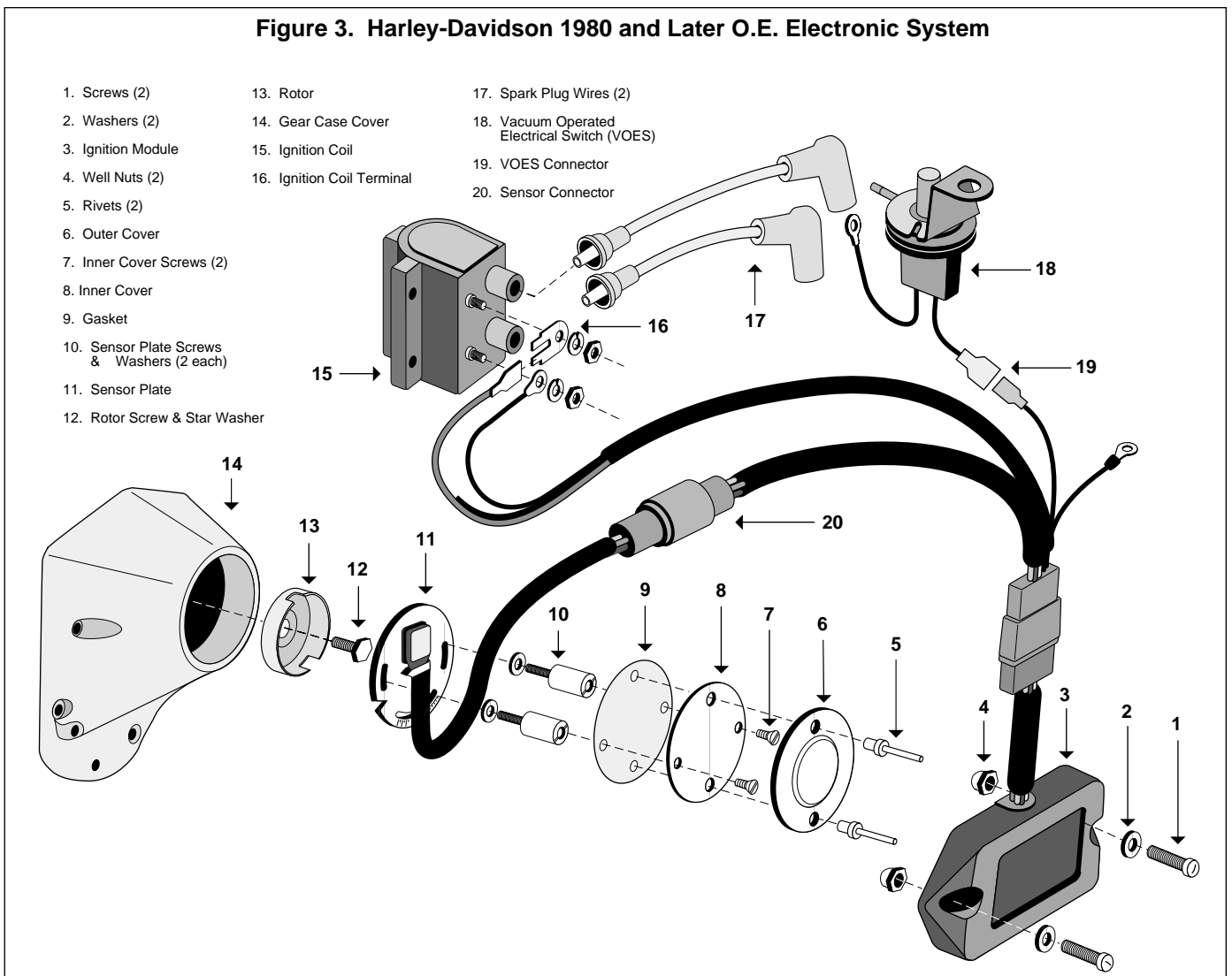
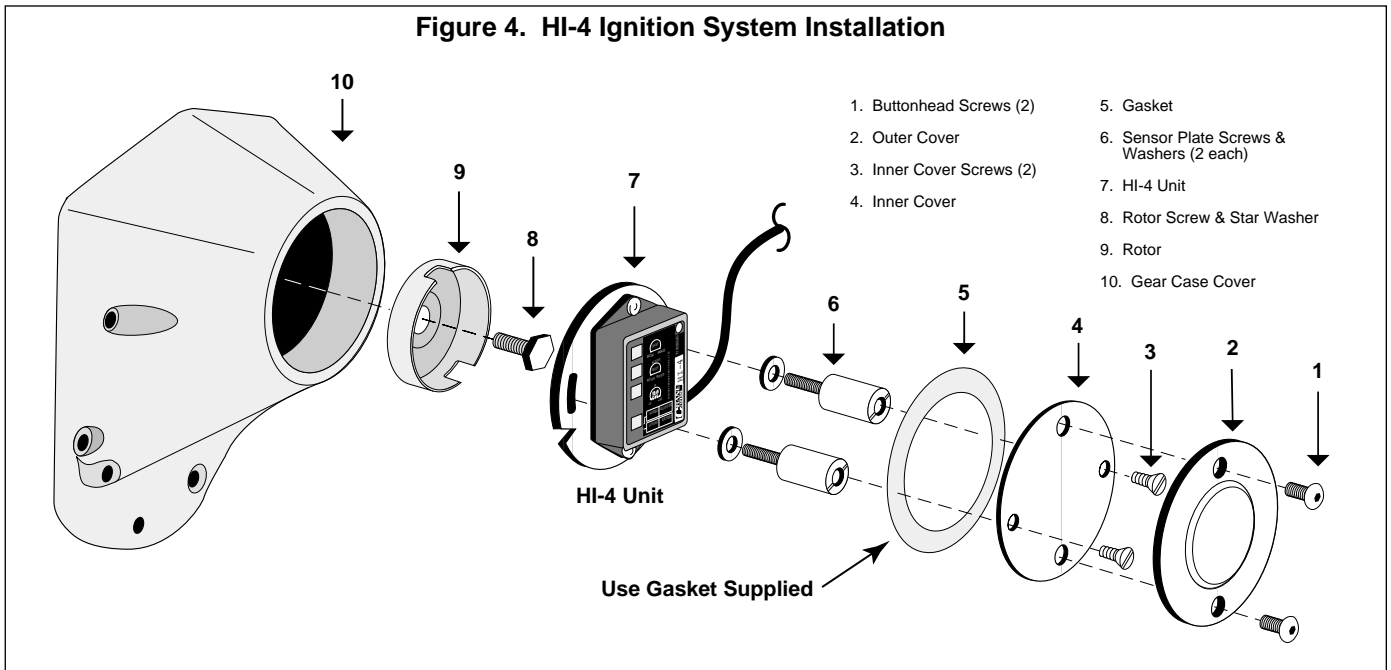

Figure 4. HI-4 Ignition System Installation



2. Route the HI-4 harness along the frame rails to the coil. Make sure that harness will not be chafed or burned by exhaust heat. Secure harness with tie wraps. Do not install timing cover.

HI-4 HOOKUP

Crimp terminals and hardware are supplied for your convenience. Use the ring terminals for coil hookup. Use male-female quick disconnects for connections to the tach and vacuum switch (VOES). Tape up any unused wires.

NOTE: At no time should the brown tach wire come in contact with +12V. Damage will result.

1. Identify switched +12 volt wire and tach wire (if equipped) going to the coil. Refer to your service manual, or reconnect the battery and use a test light or voltmeter. The switched +12 volt wire will be hot when the ignition key is turned on.
2. Refer to Figure 5 or 6, depending on your application. Connect the HI-4 red wire and switched +12 volt wire to Coil + (positive).

NOTE: Most motorcycle coils do not have terminals marked. Most single-fire coils use the center terminal for +12V and the outer two terminals for front and rear cyl Coil -. For dual-fire coils use one terminal for Coil + (positive) and the other for Coil - (negative).

3. Connect the HI-4 black wire to the Coil - terminal on the coil for the front cylinder.
4. Connect the HI-4 white wire to the Coil - terminal on the coil for the rear cylinder.

5. Connect the HI-4 green wire to the vacuum switch (Figure 3, item 18), if used.

6. Connect the HI-4 brown wire to the tach wire, if equipped with a tachometer. Tape up if unused.

7. The HI-4 is grounded via the timing housing; a separate ground connection is not required.

8. Reconnect battery ground cable. Verify proper ground connections to the frame and engine.

VACUUM SWITCH HOOKUP (READ CAREFULLY)

The H-D O.E. vacuum switch (VOES) is normally an open circuit. Above 3-5 inch-Hg vacuum, the VOES closes and grounds the vacuum input on the H-D module. This increases the total advance generated by the O.E. ignition module. Vacuum advance improves part throttle driveability and fuel economy.

The HI-4 (green wire) supports the VOES only when the "ALL OE POINTS" advance curve is selected. When the "RACE ONLY" advance curve is selected, the vacuum switch input is used for a different purpose, as explained later.

WARNING: DO NOT CONNECT A VOES TO THE HI-4 WHEN THE "RACE ONLY" ADVANCE CURVE IS SELECTED. USE THE VOES ONLY WITH THE "ALL OE POINTS" ADVANCE CURVE, WHICH HAS PROVISION FOR VACUUM ADVANCE. WHEN USING A VOES, MAKE SURE THAT THE VOES IS CONNECTED AND FUNCTIONING PROPERLY PRIOR TO SETTING THE TIMING.

Street Driven Models With O.E. Vacuum Switch (VOES). We recommend that you connect the VOES to the HI-4. If you connect the VOES, you must use the "ALL O.E. POINTS" advance curve. This will give you the best fuel economy and driveability, while protecting your engine from detonation.

NOTE: 1996 models use a 2-wire connector between the VOES and the vehicle harness. Connect one of these wires from the VOES switch to

frame ground and connect the other wire to the VOES input (green wire) on the HI-4 harness.

Street Driven Models Without O.E. Vacuum Switch (VOES). This includes most models prior to 1985. Fuel economy and driveability will be improved if you install a VOES and connect it to the HI-4. If you connect the VOES, you must use the "ALL O.E. POINTS" advance curve. We recommend you use H-D® VOES P/N 26566-91. If the VOES is not used, tape up the green wire.

Race Only Applications.

When using the "RACE ONLY" advance curve, vacuum advance is not supported. Tape up the unused green vacuum switch wire from the HI-4 or refer to the section: "EXTERNAL RETARD INPUT CAPABILITY FOR RACE ONLY ADVANCE CURVE" later in these instructions.

HI-4 SETUP AND OPERATION

Refer to the label on the HI-4. Set the two switches for your type of engine and starting preference. Kick start mode fires the first cylinder for quickest starting. Electric start mode delays firing for 2-3 revolutions of the crankshaft for smoother starts and less strain on the starter.

Trimpots on the HI-4 allow adjustment of advance and RPM limit settings. Use the screwdriver supplied in the parts kit to adjust the trimpots. Each trimpot has two slots; the end of one of the slots has two small dots on either side - this is the pointer that indicates the setting of the trimpot.

NOTE: Each trimpot can be adjusted over a range of a bit less than one full turn. At the ends of the adjustment range, mechanical stops prevent further rotation of the trimpot. **DO NOT ATTEMPT TO TURN THE TRIMPOTS PAST THEIR LIMITS.**

Figure 5. HI-4 Single Fire System Hookup with Single Plug Heads

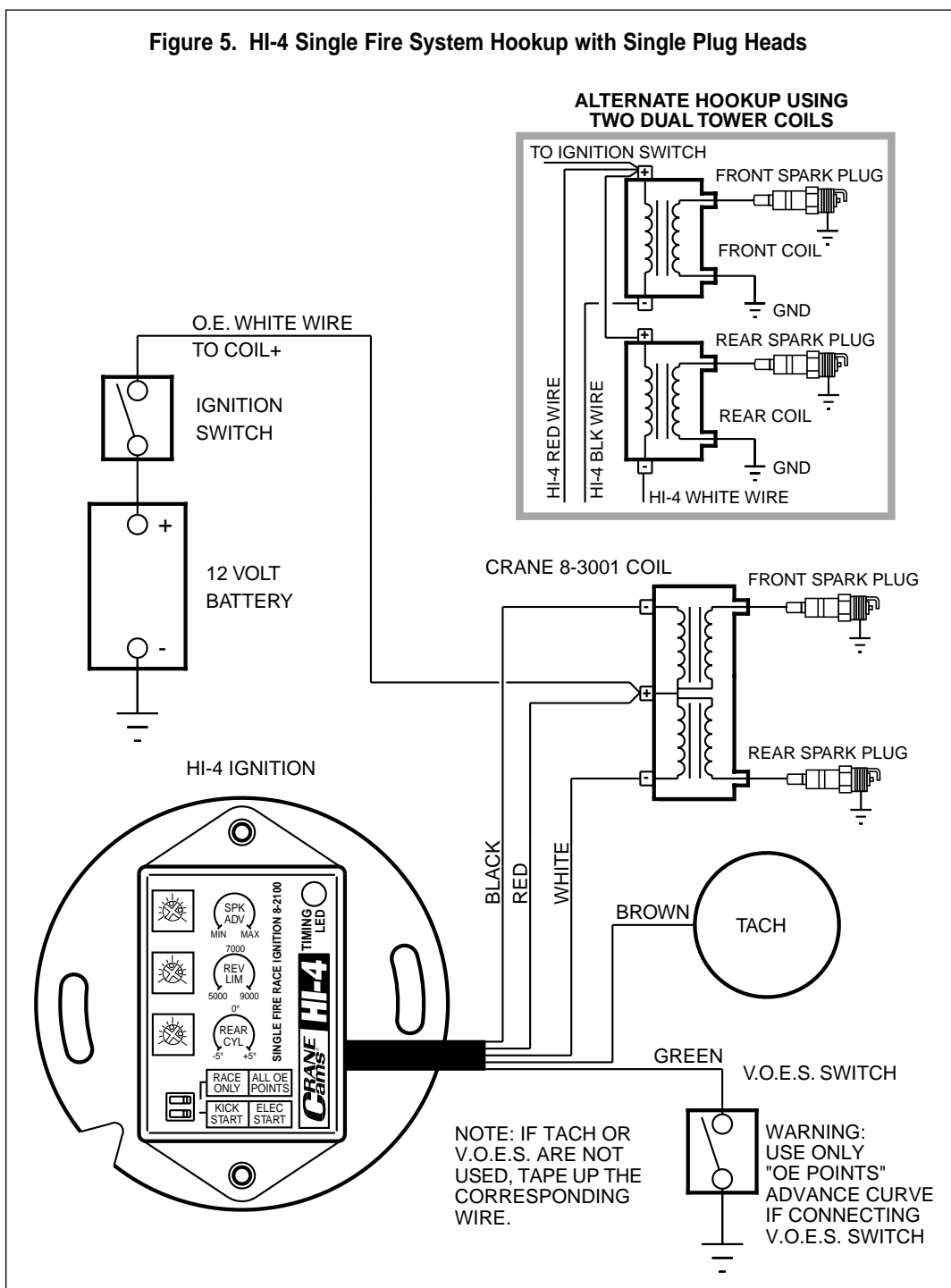

The advance curve is adjustable over a limited range via the advance trimpot. Advance curves are given in Figures 8 and 9. Each set of advance curves includes minimum and maximum curves. The actual advance curve will be between the minimum and maximum curves depending on advance trimpot setting.

If you have a passenger or are using low octane gasoline, minimum advance will reduce spark knock. Maximum advance will give higher performance, but may require the use of high octane gasoline.

An additional trimpot is provided for rear cylinder timing offset over a +/- 5 degree range. This feature allows slight offset of rear cylinder timing for critical race applications. Normally, the rear cylinder offset trimpot should be set to zero.

The RPM limit is adjustable from 5,000 to 9,000 RPM. Use a safe RPM limit for your engine.

The timing LED should light up when the ignition key is turned on. The timing LED will go off when the crankshaft is rotated past TDC. During cranking, the LED will blink.

TIMING MARKS

The TDC and advance timing marks are located on the crankshaft. Refer to Figure 7 for typical timing marks. Early Style includes most 1980 and earlier models. Late Style includes most 1981-95 models. Please refer to the shop manual for your model for details. If the shop manual is not available, remove spark plugs, turn engine until front piston is at TDC on compression stroke and identify TDC mark on the flywheel. Refer to Figure 7 and find the diagram with a matching TDC mark. Use the corresponding advance mark shown in the diagram.

NOTE: 1996 models (1995-96 for export models) have a timing mark at 20° BTDC for setting the timing with the O.E. ignition module. Do not use this mark for setting the timing on the HI-4. In

Figure 6. HI-4 Single Fire System Hookup with Dual Plug Heads

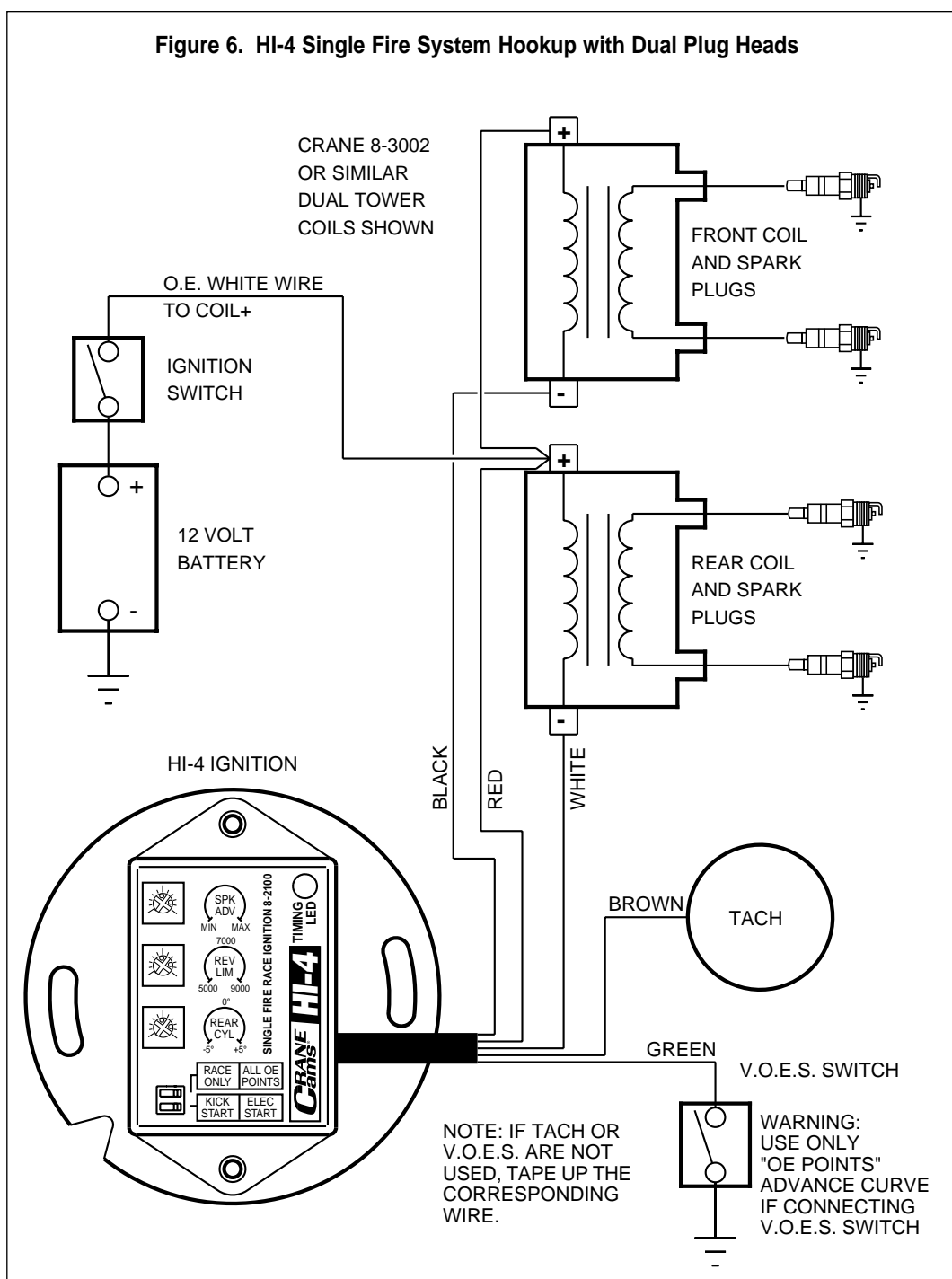

most cases an additional mark will remain at 35° BTDC (see Figure 7). Use this mark to set the timing with a timing light as described below.

OPTIONAL STATIC TIMING PROCEDURE

In most cases, aligning the V notch on the HI-4 plate to the same location as the O.E. plate will set the timing close enough to start the engine. If the engine will not start or runs very rough, you can use the following static timing procedure.

Remove spark plugs and turn engine until TDC mark appears in observation hole. Ground spark plugs with an alligator clip so you will not shock yourself. Turn on ignition. Loosen the standoffs holding HI-4 and rotate unit clockwise until timing LED goes out. The point at which LED goes off is TDC. Timing is now set approximately at TDC. Turn off ignition and reinstall spark plugs.

ADVANCE TIMING - USING TIMING LIGHT

Connect a timing light to the front cylinder. Set the HI-4 advance trimpot to midrange.

Run the engine at 2,400 to 2,500 RPM. Adjust HI-4 position until advance timing mark is centered in the observation hole. Tighten the standoffs and verify that timing has not shifted.

SETTING PRECISE ADVANCE TIMING FOR RACING - USING DIAL BACK TIMING LIGHT

Determine the advance you want at 2,500 RPM. Use a dial-back timing light. Set the amount of advance you want, say 35 degrees, on

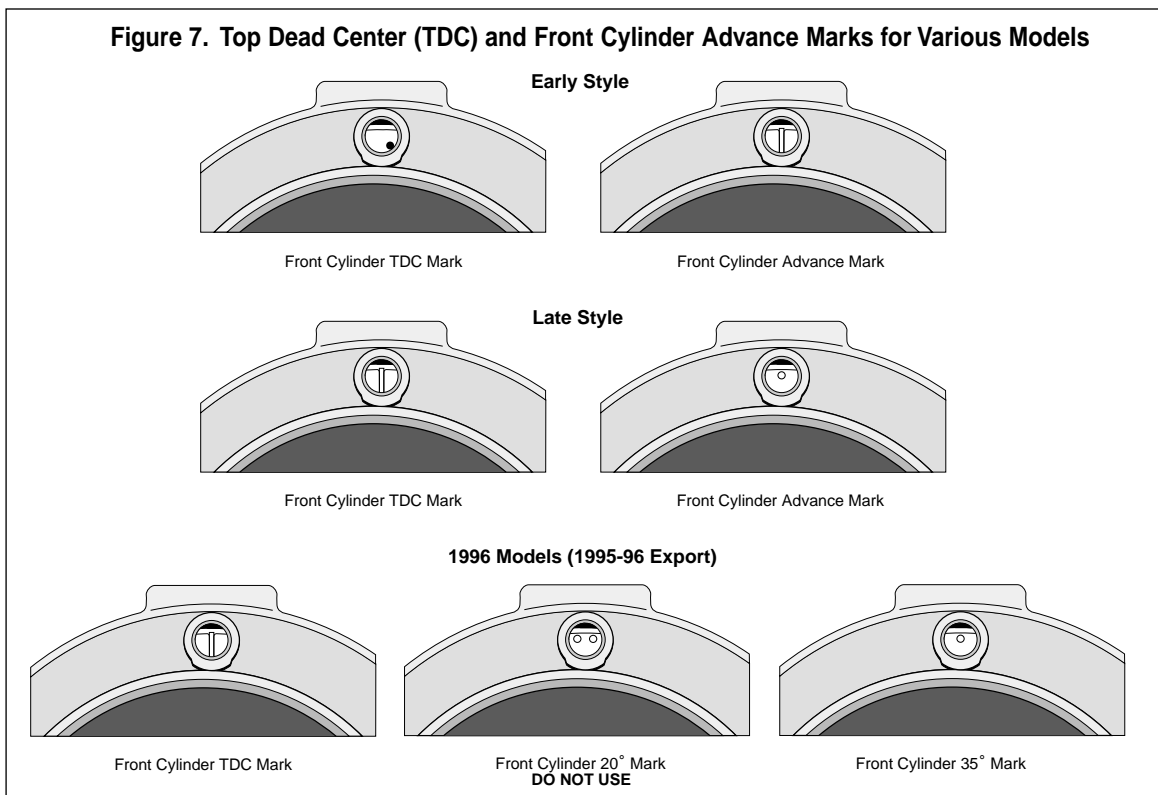

Tighten the standoffs and verify that timing has not shifted. Most dial-back timing lights will be compatible with single fire systems.

ADVANCE CURVE SETUP

After you have set the timing as explained above, set the HI-4 advance trimpot to desired position. If you run 93 octane gasoline, you can usually leave the trimpot full clockwise for maximum advance and performance without spark knock.

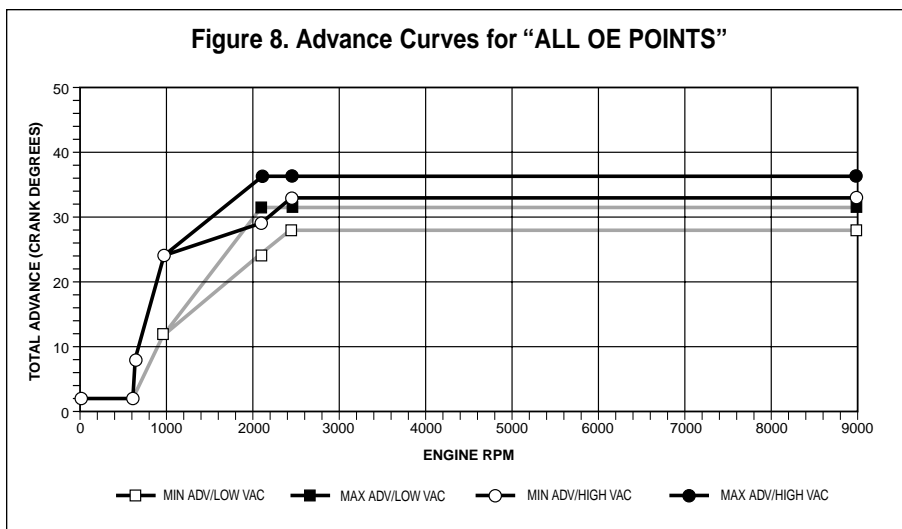

COVER PLATE ASSEMBLY

You can re-use the O.E. hardware, except use the supplied Crane gasket to provide proper clearance for the HI-4. For models with a riveted outer cover, use the supplied self-threading screws in place of the rivets.

TROUBLESHOOTING

Did the engine run properly before installation of the HI-4? If not, remove the HI-4, reinstall the O.E. ignition or another known good unit and then find and correct the original problem. Did the HI-4 function correctly before the problem occurred? If the answer is yes, did you change anything that may have affected it? Try going back to the last setup that worked OK to help isolate the problem.

the dial-back timing light. Connect the dial-back timing light to the front cylinder. Set the HI-4 advance trimpot full clockwise for maximum advance. Run the engine at 2,500 RPM. Adjust HI-4 position until TDC timing mark is centered in the observation hole. You will now have the amount of advance you dialed into the timing light.

If the engine will not start, or runs rough or intermittently, use the following checklist steps:

ENGINE WILL NOT START

Check that timing LED lights up when ignition key is

first turned on. If not, check for +12 volts on red wire from HI-4.

Check that timing LED blinks while engine is cranked. If not, HI-4 may be defective.

If the timing LED blinks, but engine will not start, recheck all wire harness connections or replace coil(s).

CHECKING FOR SPARK

WARNING: NEVER CRANK THE ENGINE WITH ANY SPARK PLUG WIRE DISCONNECTED.

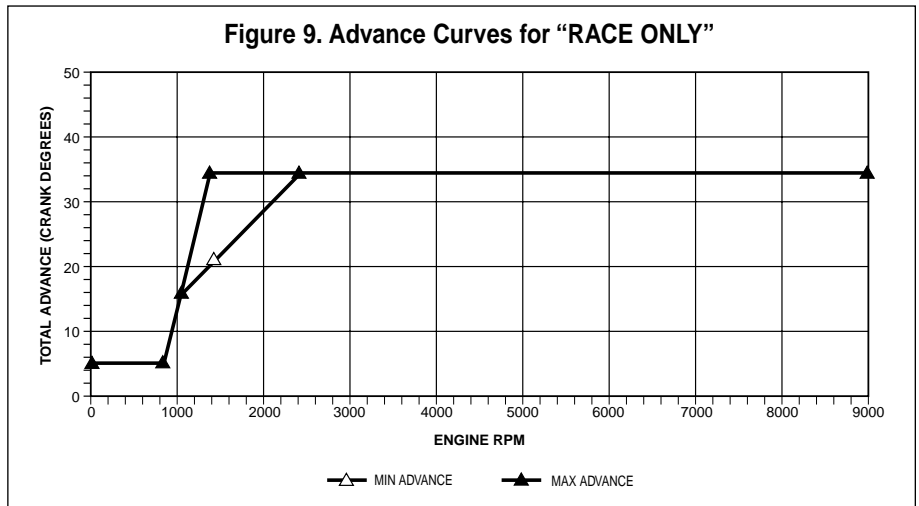

To crank the engine and check for spark, use a KD Tools test plug or H-D tool HD-26792. These test plugs come with an alligator clip that must be attached to frame or engine ground. Use a length of spark plug wire to connect the test plug to the coil.

MISFIRE OR INTERMITTENT OPERATION

Field experience has shown that popping back through the carburetor, misfiring, and intermittent failure (especially after the engine gets hot) are usually not caused by electrical problems within the HI-4. Carburetor problems, fouled spark plugs, coil failure, and loose wire harness connections are the most common culprits.

TACH INOPERATIVE

If the tach is inoperative after installation of the HI-4, you may require a tach adapter. The HI-4 tach output is compatible with ground sensing tachs which includes most O.E. and aftermarket tachs. Some tachs require a high voltage trigger pulse. In this case, install Crane tach adapter P/N 8-2050.

EXTERNAL RETARD INPUT CAPABILITY FOR RACE ONLY ADVANCE CURVE

When the "RACE ONLY" advance curve is selected, the vacuum switch input (green wire) can be used to command up to 12 degrees of retard. This feature is useful for turbo/supercharger, drag race high gear retard, or nitrous oxide injection applications. To use this retard feature, the green wire is connected to a 10K pot (potentiometer), which in turn is connected via a switch to ground as shown in Figure 10. The 10K pot is used to set the amount of retard. When the switch is closed, the retard feature is activated. A sealed MIL-SPEC 10K potentiometer (Clarostat RV4LAYS103A) with locking shaft is available from Newark Electronics (312-638-7652).

For turbo/supercharger applications, a pressure switch can be used to activate the retard once a certain boost pressure is reached. NAPA Balkamp offers two adjustable boost pressure switches that can be used in this application: P/N 701-1591 (3-7 psig range) and P/N 701 1603 (1.1-3 psig range).

