

Instruction sheet No. 2027  
Revised 3-15-96

Copyright ©, 1986, 1995, 1996  
by S&S Cycle, Inc.  
All rights reserved. Printed in the U.S.A.

*S&S Cycle, Inc.*

Box 215

Viola, Wisconsin 54664

Phone 608-627-1497

Fax 608-627-1488



## Installation Instructions for S&S Big Twin Pinion Shafts #33-2024 and #33-2027

### Product Information

S&S pinion shaft kit, **part #33-2024**, has been designed as a composite replacement and is made to fit stock H-D flywheels and S&S SE and L style flywheels in 1958 to early 1981 Big Twin engines. It can also be used in 1954 to 1957 engines, if crankcases are modified. S&S #33-2024 shaft effectively replaces H-D Part #24006-54A, #24006-58 and #24006-73.

To use S&S pinion shaft #33-2024 in 1954 to 1957 crankcases, perform the following operations:

1. Remove pressed-in bearing race in the right crankcase.
2. Bore cast-in bearing retainer out to 2.125" to accept larger diameter later 1958 to 1981 press-in race.
3. A shim must be fabricated to space later pressed-in bearing race out to earlier bearing race position.

The S&S pinion shaft kit, **part #33-2027**, is designed to fit stock H-D flywheels from late 1981 to 1989 and S&S SL and BL style flywheels for late 1981 and later engines. S&S #33-2027 replaces H-D part #24006-80, #24006-83 and #24006-87. S&S pinion shaft kits, parts #33-2028 and 33-2029, are identical to #33-2027 in design and application except they have bearing surface diameters of +.001" and +.002" oversize respectively. S&S Shaft #33-2028 replaces H-D #24020-87 and shaft #33-2029 replaces H-D #24021-87.

*NOTE - When using S&S #33-2027 pinion shaft in 1990 and later engines with S&S flywheels, pre-1989 oil pump drive gear and pinion gear must be used as stock gears for 1990 and later style, straight pinion shaft will not fit S&S shaft.*

### Installation Procedure

1. Thoroughly clean shaft and blow air through oil holes in both ends of shaft to insure no foreign material is trapped in oil passageway.
2. **#33-2024 only** - Press brass plug in gear cover end of shaft until it bottoms against shoulder in hole. For engines 1954 to 1972 with side oiling gear covers, use solid plug. For 1973 to early 1981 engines with end oiling gear covers, use plug with  $\frac{3}{32}$ " hole.

### NOTES

- When S&S pinion shaft #33-2024 is used in 1973 to 1981 engines with end oiling gear covers, side oiling feed hole for 1954 to 1972 engines does not have to be plugged. Amount of oil lost through side oil feed hole in bearing surface of shaft is insignificant if gear cover bushing is fit correctly to end of pinion shaft.
- In 1954 to 1972 engines, oil is fed to connecting rods once per revolution, through an oil hole in side of pinion shaft bearing surface. Oil hole in pinion shaft aligns with oil feed hole in pinion shaft bushing pressed in gear cover. Later engines, 1973 to present, feed oil continuously to connecting rods through a hole in end of pinion shaft. Before proceeding, check your gear cover to determine which of these

*oiling systems your engine uses. Early engines from 1954 to 1972 which have been converted with a special gear cover bushing to oil connecting rods using 1973 to present style oiling methods require brass plug with drilled oil metering hole - follow instructions for 1973 and later engines.*

- If a 1972 or earlier gear cover is converted to end feed style oiling, or if a groove is machined around bearing surface of pinion shaft to allow oil to feed continuously, low oil pressure will result unless crankcase and oil pump are also updated to 1973 and later oiling system.

### CAUTIONS

- Low oil pressure due to use of 1973 and later style end oiling pinion shaft in 1972 and earlier engines may cause overheating, premature wear, and damage to engine components.

- Installing solid end plug in 1973 and later engines will result in insufficient oil flow to connecting rods, causing premature wear and damage to connecting rod bearings and other internal engine components.

3. Inspect key ways and oil holes in flywheels for burrs. Remove burrs if necessary.

*NOTE - S&S does not recommend lapping tapers to remove burrs. This practice tends to distort the taper by removing material unevenly around the circumference. This makes flywheels difficult if not impossible to true. In addition the lapping process work hardens the surface of the taper. The resultant hard surface makes it very difficult to pull shaft into taper. Lapped flywheel tapers are also very difficult to resurface if repairs are ever needed.*

4. Check keys in key ways of shaft. Keys should be light hand press fit in key ways. If key is too tight in key way, sand side of key with fine sand paper on a metal plate or other flat surface. Do not hammer key into key way.

**CAUTION - Hammering tight key into key way may result in irreparable damage to shaft.**

5. With key in shaft, insert into respective tapered hole in flywheel and check to see that key does not bottom in key way of flywheel taper. If key bottoms out, file or sand flat side of key, not rounded side, until shaft with key in place fits in flywheel without bottoming out.
6. Assemble flywheel and shaft. Use stock factory torque specifications (140 to 170 ft. lbs.) in stock, cast iron flywheels. For S&S forged steel flywheels tighten nut to 275 to 300 ft. lbs. S&S recommends that green loctite (RC609) or similar thread locking product be used on taper of shaft, threads of shaft, and face of nut.
7. Blow air through connecting rod oil feed hole in end of pinion shaft after flywheel, crankpin and pinion shaft have been assembled to insure that passageway is open.



Picture 1  
Stock 1981-1986 Style Flywheel

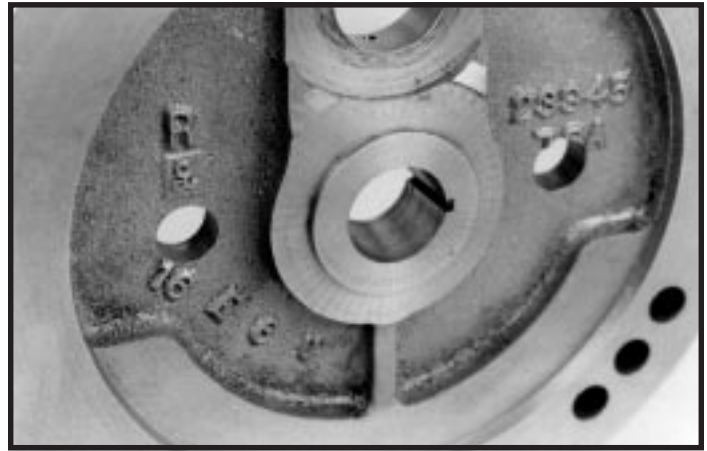

Picture 2  
Stock 1987-1989 and S&S 1981-Up Flywheel

**CAUTION - Restricted or blocked oil passage may result in insufficient oil flow, and cause premature wear and damage to internal engine components.**

8. Finish assembling and truing flywheels.
9. Select correct size main bearings per H-D factory procedures. Consult appropriate H- D manual for style of bearings used.
10. Install main bearings on pinion shaft.

#### NOTES

- Stock flywheel thrust washer must be installed against flywheel in 1954 engines only. For clarity, this washer is not shown in pinion bearing diagrams on pages 3 and 4.
- There are two styles of flywheels which will accept the S&S #33-2027 pinion shaft. Stock 1981 to 1986 style flywheels are machined with a small diameter shoulder around the pinion shaft taper to accept a main bearing thrust washer. **See Picture 1.** Stock 1987 to 1989 and all current production S&S flywheels for late 1981 and later engines, are machined with a large diameter shoulder around the pinion shaft taper. This shoulder is designed to eliminate the main bearing thrust washer previously used. **See Picture 2.**
- There are three types of pinion main bearings which may be used with S&S #33-2024 and #33-2027 pinion shafts. **Picture 3** shows the 1958 to 1986 style bearings which consist of two open ended steel cages and drop in roller bearings. The 1987 to 1993 style (FAG) bearings consist of two stamped steel cages with roller bearings installed. **See Picture 4.** Bearings from 1994 consist of one stamped steel cage with a single row of rollers installed. **See Picture 5.**
- The combinations of thrust washers and bearings shown in this instruction sheet are typical for most installations. Individual circumstances may, however, require that engine builder space

bearings in a different manner. Engine builder must insure that bearing assembly rotates freely on pinion shaft and that rollers are positioned so they are entirely supported by the bearing race.

● There is no specification for pinion bearing assembly end play. A good rule of thumb is that if an additional thrust washer can be installed and bearings can still rotate freely, and are still supported by race, install it. If not, leave it out.

#### A. 1954-1986 style bearings

1. 1954 to Early 1981 stock flywheels or S&S SE or L style flywheels, and S&S pinion shaft #33-2024 - Two .070" thrust washers are normally used. Typical washer and bearing arrangement - .070" washer against flywheel, bearings, .070" washer, and snap ring. **See Figure 1.**
2. 1981- 1986 style stock flywheels and S&S pinion shaft #33-2027 - Two .070" thrust washers and one .050" thrust washers are normally used. Typical washer and bearing arrangement - .070" washer against flywheel, bearings, .070" washer, .070" or .050" washer, and snap ring. **See Figure 2.**
3. 1987 to 1989 stock flywheels or S&S SL or BL flywheels for 1981 and later, and S&S pinion shaft #33-2027 - One .070" thrust washer and one .050" thrust washer are normally used. Typical washer and bearing arrangement - .050" washer against flywheel, bearings, .070" washer, and snap ring. **See Figure 3.**

**NOTE - It may be necessary to install bearing cages so that open side faces flywheel in order to position rollers entirely on the bearing race.**



Picture 3  
1958-1986 Style Bearings



Picture 4  
1987-1993 Style Bearings

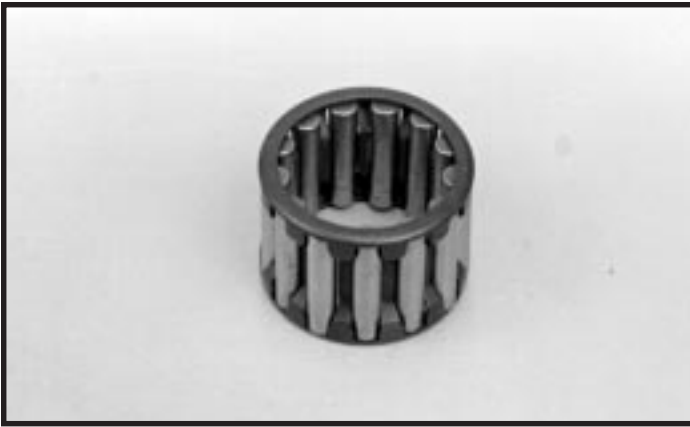

**Picture 5**  
**1994-Up Style Bearings**

- B. 1987 to 1993 style bearings
1. 1954 to Early 1981 stock flywheels or S&S SE or L style flywheels and S&S pinion shaft #33-2024 - No thrust washers are normally used. Typical bearing arrangement - bearings against flywheel and snap ring. **See Figure 4.**
  2. 1981 to 1986 style stock flywheels and S&S pinion shaft #33-2027 - Extra .070" main bearing thrust washer supplied in kit is normally used. Typical washer and bearing arrangement - .070" washer against flywheel, bearings, and snap ring. **See Figure 5.**
  3. 1987 to 1989 stock flywheels or S&S SL or BL style flywheels for 1981 and later, and S&S pinion shaft #33-2027 - No thrust washers are normally used. Typical arrangement - Bearings against flywheel, and snap ring directly against bearing. **See Figure 6.**
- C. 1994 and later single roller style bearings

*NOTE - Late style larger diameter bearing retaining clip S&S #31-4021 or H-D #11177A must be used with late style 1994 and later single roller pinion bearings. Earlier style smaller diameter retaining clip may not sufficiently contact late style bearing cage to safely hold bearing cage in place. Refer to H-D Service Bulletin M-1042, 4-19-94. S&S recommends that late style retaining clip be used with all types of pinion bearings.*

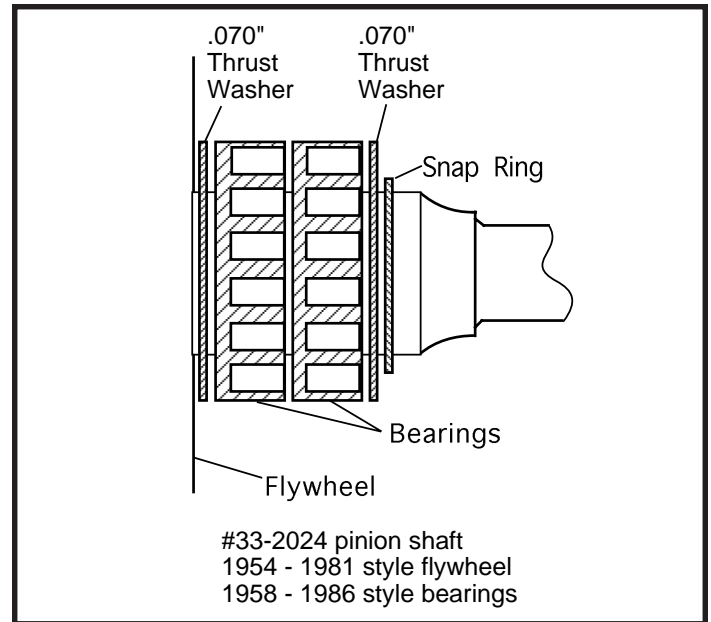

**Figure 1**

**CAUTION - Use of earlier style retaining clip with late style single roller bearing may result in bearing failure and serious engine damage.**

1. 1954 to Early 1981 stock flywheels or S&S SE or L style flywheels and #33-2024 - No thrust washers are normally used. Typical bearing arrangement - bearings against flywheel and snap ring. **See Figure 7.**
  2. 1981 to 1986 style stock flywheels - Two .050" thrust washers are normally used. Typical arrangement - .050" washer, bearing cage, .050" washer, and snap ring. **See Figure 8.**
  3. 1987 to 1989 stock flywheels or S&S SL or BL flywheels for 1981 and later, and S&S pinion shaft #33-2027 - No thrust washers are normally used. Typical arrangement - Bearing cage against flywheel, and snap ring directly against bearing cage. **See Figure 9.**
11. Install flywheel assembly in driveside crankcase. Temporarily install camside crankcase. Check to be sure pinion bearing rollers are fully supported by bearing race. Adjust bearing spacing as needed.

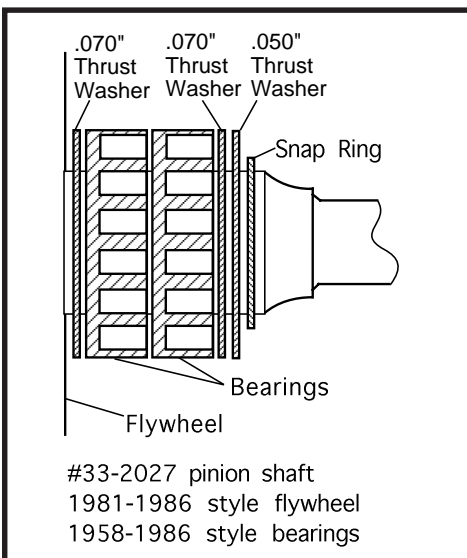

**Figure 2**

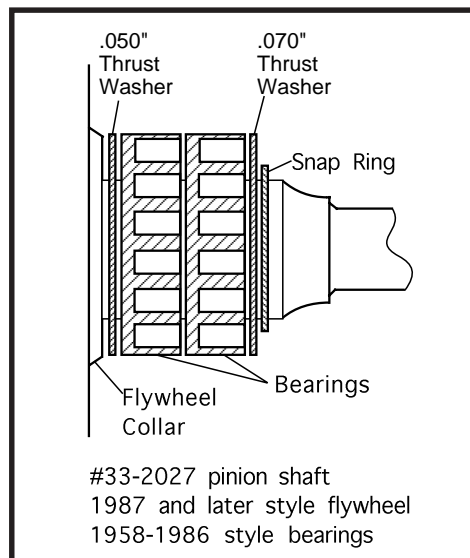

**Figure 3**

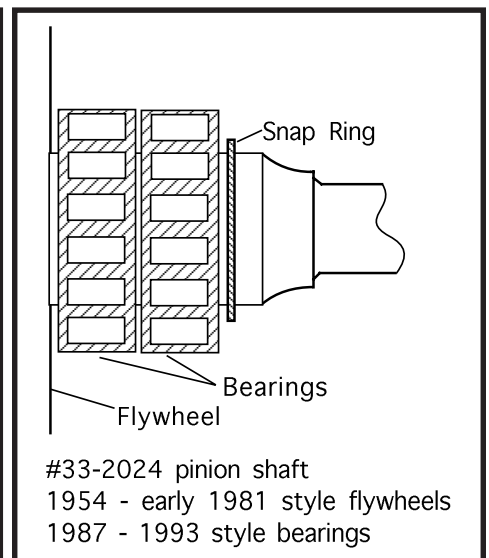

**Figure 4**

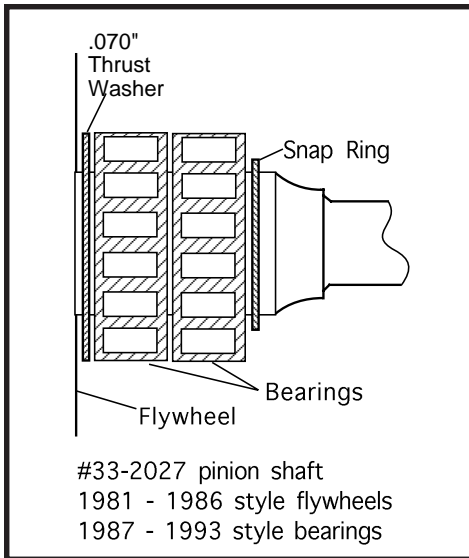

Figure 5

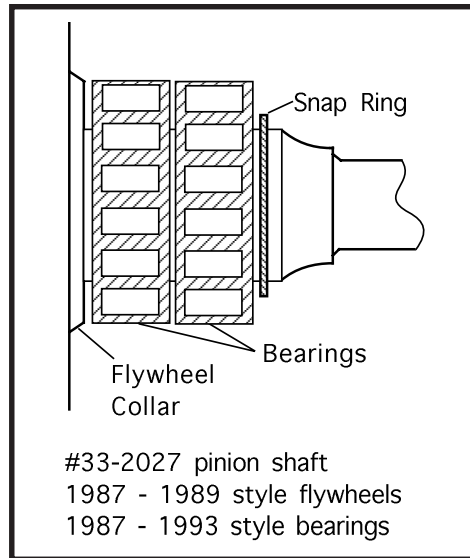

Figure 6

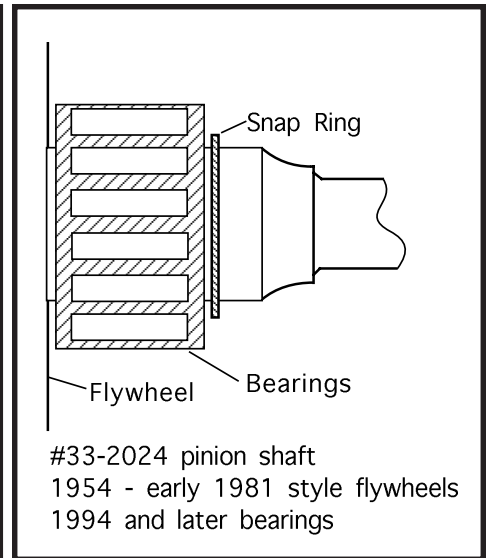

Figure 7

## NOTES

- Final placement of flywheel thrust washers is determined by position of main bearings in main bearing race. Main bearings should be spaced so rollers are completely supported by race surface.
- Thin thrust washers placed between flywheel and bearing cage will sometimes drop between flywheel collar and bearing surface of pinion shaft. A slightly thicker thrust washer will usually solve this problem. Also, thrust washers normally have a larger inside chamfer on one side of washer than on other side. Placing smaller chamfer toward bearing cage will help minimize this problem. Thrust washers of various thickness can be obtained from local bearing houses. Custom thickness thrust washers can be made by surface grinding a thicker thrust washer.

12. Final assemble crankcases.

13. Install oil pump drive gear, spacer, and pinion gear on pinion shaft. Apply loctite to threads of pinion gear nut and torque to 45 ft.lb.

## NOTES

- Oil pump drive gear spacer will not completely fill gap between oil pump drive gear and pinion gear. A gap of up to .125" may exist, and is normal. Function of spacer is to prevent pinion shaft oil pump drive

gear from disengaging from oil pump drive shaft gear if engine is turned backward. During normal operation, oil pump drive gear is pulled toward pinion shaft bearing boss.

- Be sure oil pump drive gear is installed with chamfered side toward pinion shaft bearing boss. See **Figure 10**.

**CAUTION -** If oil pump drive gear is installed with sharp edge against radius on pinion shaft bearing boss, sharp edge may nick radius. This can result in a stress riser that may cause shaft to break. See **Figure 10**.

14. Install cam, breather gear, and gear cover according to H-D factory procedure.

*NOTE -* Gear cover should slide into place with little or no resistance. If gear cover will not slide on easily, cause of resistance must be determined and corrected. Under no circumstances should cover be forced into place.

**CAUTION -** Forcing gear cover on may subject pinion shaft to unwarranted side loading and flexing which during operation can cause shaft to fatigue and break.

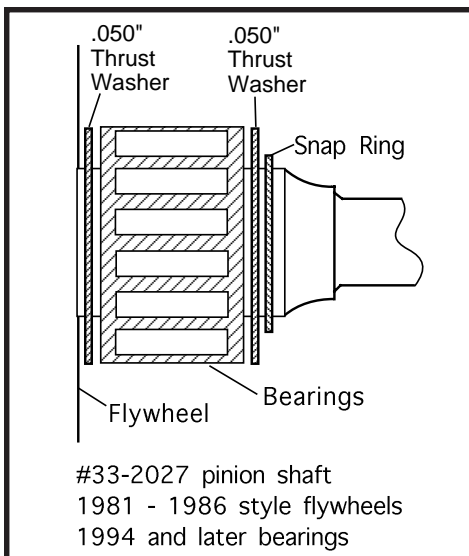

Figure 8

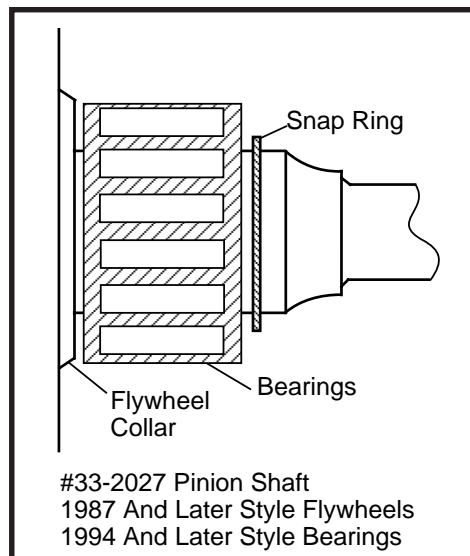

Figure 9

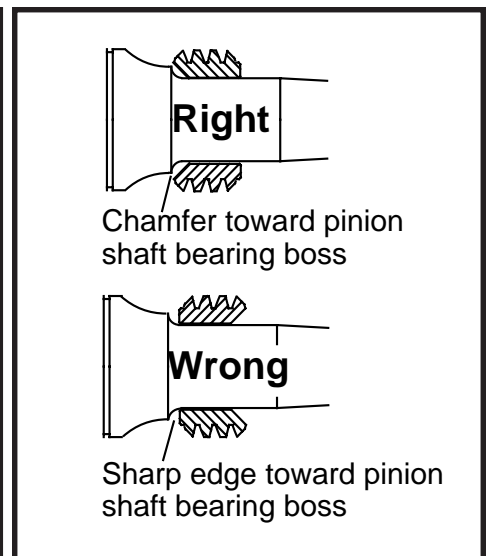

Figure 10